

ANALYTICAL SOLUTION OF BASIC EQUATIONS OF THEORY OF STRUCTURES FOR CABLE-STAYED BRIDGES

Géza Tassi
Pál Rózsa
Mátyás Hunyadi

Rakenteiden Mekaniikka, vol 37
No. 3, 2004, pp. 18-33

SUMMARY

The paper deals with the determination of forces in cable-stayed bridges by the deformation method and the force method. Using methods of linear algebra, it gives an analytical solution for determination of the internal forces in such structures.

INTRODUCTION

It is well known that two basic methods are used to calculate the redundant forces in statically indeterminate structures: the force method and the deformation methods. In the engineering practice, both of them need to take up a primary system. The unknowns are produced in both cases by solving a linear system of equations. Taking up the primary system, the following points of view are to be considered: the quantity of unknowns, the form of the coefficient matrix and the form of the load vector.

In case of a typical arrangement of cable-stayed bridges, both procedures find place. This paper shows both methods giving an analytical solution.

The coefficient matrix of the system obtained by the deformation method is a two by two block matrix with tridiagonal blocks. After an appropriate rearrangement of the rows and columns, the coefficient matrix can be transformed into an n by n block tridiagonal matrix consisting of blocks of second order. The blocks of the inverse can be calculated by the help of recursive formulae. The method has the advantage that operations have to be performed using second order matrices only.

Applying the force method, the chosen primary system leads to a system of equations having a pentadiagonal coefficient matrix. Because of the complexity of the task, even in the case of the regular form of the bridge, the solution is given by a recursion. The discussed statical system will be the same in both cases.

The application of matrix theory for suspension bridges has a considerable tradition in Hungary [2]

THE STATIC SYSTEM

The cable arrangement, the form of the towers and the stiffening girders are rather various [3][5]. For the sake of simplicity, we suppose in the following, that there is a single plane of cables and the structure has one bay. Also, it will be supposed, that the tower is absolutely rigid, both ends of the girder are constrained, all cables are fixed to the top of the tower and they are connected to the stiffening girder at equidistant points at the level of its C. G. The flexural stiffness of the girder is constant, the axial and shear deformations are neglected. The cross section of all cables is the same (Fig. 1). The first order theory will be applied 0.

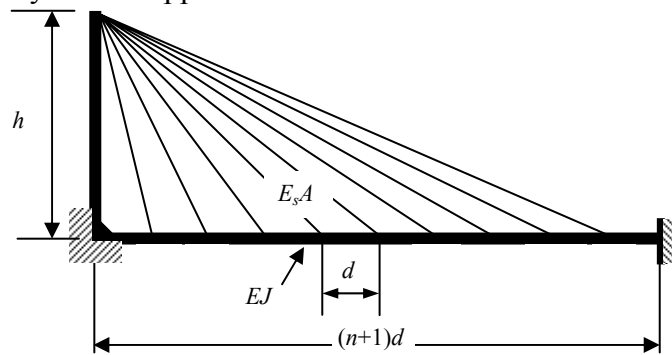

Fig. 1 The computational model

APPLICATION OF THE DEFORMATION METHOD

The primary system

Using the deformation method means that the primary system is gained from Fig. 1 by fixing nodes 1, 2, ..., n against rotation and vertical displacement. The corresponding arrangement is shown in Fig. 2. The number of unknowns is twice the number of cables.

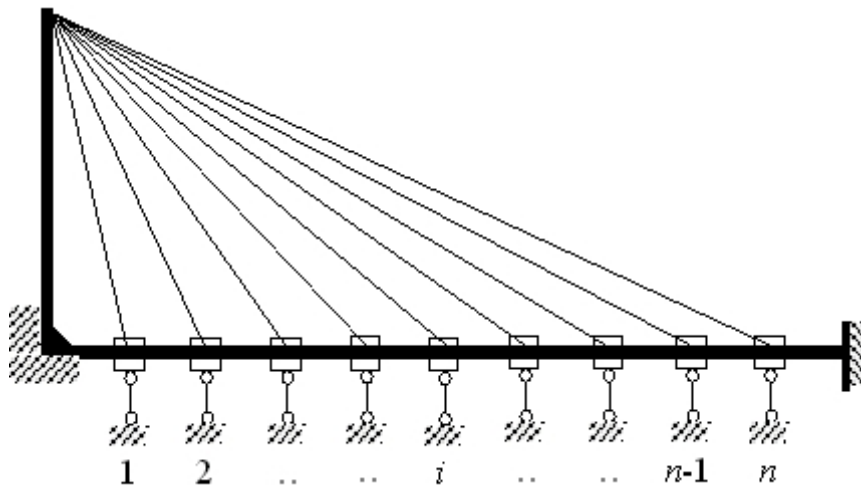

Fig. 2 The primary system for the deformation method

For a more detailed explanation, let us give the physical meaning of the blocks.

Block **A** contains the unit coefficients D_{ij} which relate to the moments at nodes i due to a unit negative rotation at points j on the primary system. (Clockwise rotation is negative).

In block **G** the moments at points i are given due to the unit deflection at point j ($D_{i,n+j}$). Block \mathbf{G}^T gives the unit coefficients $D_{n+i,j}$, i.e. the vertical forces occurring at nodes i due to the unit rotation at point j .

The elements $D_{n+i,n+j}$ of block **L** are the vertical forces at points i from the flexural resistance of the stiffening girder, w and c_i represents the vertical component of the cable force.

The unknowns and the load vector

In Eq. (1) the unknowns are the rotations φ_i and the deflections η_i of nodes i ($i=1, 2, \dots, n$) of the original structure.

The upper part \mathbf{m} of the load vector gives the moments M_i acting on the nodes i of the primary system due to the external load and the vector \mathbf{f} gives similarly the forces F_i .

The solution of the matrix equation

To receive the φ_i, η_i values of Point 3.2 Eq. (1) is to be solved. The solution can be written in form

$$\begin{bmatrix} \varphi \\ \eta \end{bmatrix} = -\frac{1}{EJ} \begin{bmatrix} \mathbf{A} & \mathbf{G} \\ \mathbf{G}^T & \mathbf{L} \end{bmatrix}^{-1} \begin{bmatrix} \mathbf{m} \\ \mathbf{f} \end{bmatrix}. \quad (3)$$

Transformation of the coefficient matrix

Since the diagonal elements in block **L** are depending on i , the nice block structure of the coefficient matrix does not seem to be expedient for the calculation of the inverse. Instead of this, we reorder the equations and the unknowns in such a way, that the coefficient matrix becomes an n -th order block matrix consisting of blocks of second order.

The reordering of the system

Let us consider the following permutation of the indices $1, 2, \dots, i, \dots, n, n+1, n+2, \dots, n+i, \dots, 2n$, i.e. $1, n+1, 2, n+2, \dots, i, n+i, \dots, n, 2n$.

Rearranging the rows and columns of the coefficient matrix and the elements of the unknown vector and those of the load vector, the following system can be obtained. The system is given here for $n=4$ (see Fig. 3):

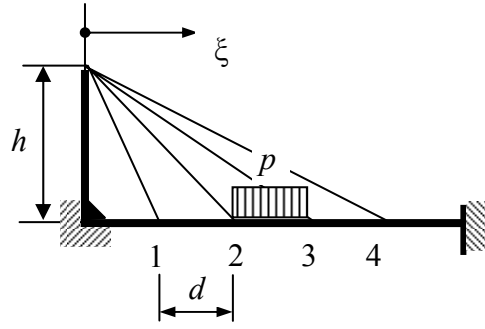

Fig. 3 A simple case for $n=4$

$$\mathbf{t} = \begin{bmatrix} 0 \\ 0 \\ M_t \\ -F_t \\ -M_t \\ -F_t \\ 0 \\ 0 \end{bmatrix}, \text{ where } M_t = \frac{pd^2}{12} \text{ and } F_t = \frac{pd}{2}.$$

Since the blocks of the upper (and also the lower) codiagonal are equal, the next step is to diagonalise them. Taking into consideration that

$$\mathbf{V}^T \begin{bmatrix} a & -g \\ g & -w \end{bmatrix} \mathbf{U} = \begin{bmatrix} 1 + \frac{\sqrt{6}}{2} & 0 \\ 0 & 1 - \frac{\sqrt{6}}{2} \end{bmatrix} = -\mathbf{H} \quad (5)$$

and

$$\mathbf{V}^T \begin{bmatrix} a & g \\ -g & -w \end{bmatrix} \mathbf{U} = \begin{bmatrix} 1 - \frac{\sqrt{6}}{2} & 0 \\ 0 & 1 + \frac{\sqrt{6}}{2} \end{bmatrix} = -\mathbf{B}, \quad (6)$$

where

$$\mathbf{U} = \begin{bmatrix} \frac{1}{\sqrt{2a}} & \frac{1}{\sqrt{2a}} \\ -1 & 1 \\ \frac{1}{\sqrt{2w}} & \frac{1}{\sqrt{2w}} \end{bmatrix} \text{ and } \mathbf{V}^T = \begin{bmatrix} \frac{1}{\sqrt{2a}} & \frac{1}{\sqrt{2w}} \\ \frac{1}{\sqrt{2a}} & -1 \\ \frac{1}{\sqrt{2a}} & \frac{1}{\sqrt{2w}} \end{bmatrix},$$

furthermore

$$\mathbf{Y}_i = \mathbf{V}^T \begin{bmatrix} 4a \\ 2w + \beta c_i \end{bmatrix}, \quad \mathbf{U} = \begin{bmatrix} 1 & 3 \\ 3 & 1 \end{bmatrix} - \frac{\beta d^3}{24} c_i \begin{bmatrix} 1 & -1 \\ -1 & 1 \end{bmatrix}, \quad (7)$$

$$\begin{aligned} \mathbf{T}_2 &= \mathbf{T}_1 \mathbf{Y}_1 \mathbf{H}^{-1} \\ \mathbf{T}_{i+1} &= (\mathbf{T}_i \mathbf{Y}_i - \mathbf{T}_{i-1} \mathbf{B}) \mathbf{H}^{-1} \quad i = 2, 3, \dots, n-1 \end{aligned}$$

Hence the solution of (8) is obtained:

$$EJ \mathbf{x} = -[\mathbf{UR}_{ij} \mathbf{V}^T] \mathbf{t}$$

where \mathbf{x} and \mathbf{t} contain the unknowns and the load coefficients respectively as shown in Eq. (4).

The internal forces of the bridge

According to the principle of the deformation method [6], the moments of the stiffening girder at a cross section ξ can be calculated as follows:

$$M_\xi = \sum_1^n M_\xi(\varphi_k) + \sum_1^n M_\xi(\eta_k) + M_{\xi 0}, \quad k = 1, 2, \dots, n.$$

Here $M_\xi(\varphi_k)$ and $M_\xi(\eta_k)$ are the moments at cross section ξ due to the calculated rotation φ_k and deflection η_k resp. The value $M_{\xi 0}$ is the moment at section ξ of the primary system due to external loads. The shear forces are to be calculated similarly. The cable forces can be written as

$$S_k = E_s A_s \eta_k c_k \frac{\sqrt{h^2 + k^2 d^2}}{h}, \quad k = 1, 2, \dots, n,$$

where c_k is defined in Eq. (2).

THE SOLUTION BY THE FORCE METHOD

In several cases, the application of the force method is more convenient than the deformation method (e.g. for the case of the adjustment of the stay cables or yielding of structural members 0). Nevertheless, to show the difference, in this paper, both methods will be applied for the same problem, i.e. for a uniform load between two joining points of cables (Fig. 3, Fig. 5).

The primary system

Let us remind that the axial deformation of the stiffening girder is neglected. This condition enables to take the primary system as shown in Fig. 4. It is formed by applying hinges at both constrained ends and at the joining points of cables along the girder.

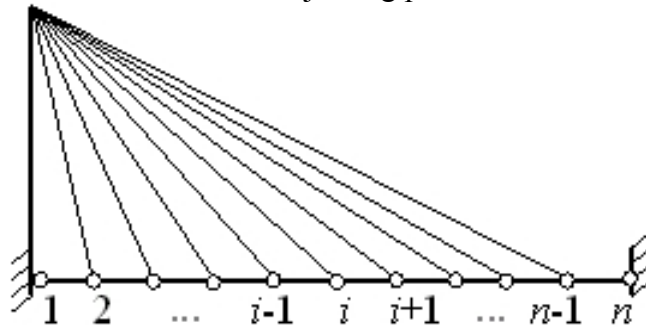

Fig. 4 The primary system for the force method

$$\begin{aligned}
a_{11} &= \frac{1}{3} \frac{d}{EJ} + \frac{1}{E_s A d^2 h^2} l_2^3, \\
a_{12} &= \frac{1}{6} \frac{d}{EJ} - \frac{2}{E_s A d^2 h^2} l_2^3, \\
a_{13} &= \frac{1}{E_s A d^2 h^2} l_2^3, \\
a_{22} &= \frac{2}{3} \frac{d}{EJ} + \frac{1}{E_s A d^2 h^2} \{4l_2^3 + l_3^3\}, \\
a_{ii} &= \frac{2}{3} \frac{d}{EJ} + \frac{1}{E_s A d^2 h^2} \{l_{i-1}^3 + 4l_i^3 + l_{i+1}^3\}, \\
a_{i,i+1} &= \frac{1}{6} \frac{d}{EJ} - \frac{2}{E_s A d^2 h^2} \{l_i^3 + l_{i+1}^3\}, \\
a_{i,i+2} &= \frac{1}{E_s A d^2 h^2} l_{i+1}^3, \\
a_{n-1,n-1} &= \frac{2}{3} \frac{d}{EJ} + \frac{1}{E_s A d^2 h^2} \{l_{n-2}^3 + 4l_{n-1}^3\}, \\
a_{n,n-1} &= \frac{1}{6} \frac{d}{EJ} - \frac{2}{E_s A d^2 h^2} l_{n-1}^3, \\
a_{n,n-2} &= \frac{1}{E_s A d^2 h^2} l_{n-1}^3, \\
a_{nn} &= \frac{1}{3} \frac{d}{EJ} + \frac{1}{E_s A d^2 h^2} l_{n-1}^3,
\end{aligned}$$

where $l_i = \left\{ h^2 + (i-1)^2 d^2 \right\}^{\frac{1}{2}}$, $i = 2, 3, \dots, n$.

The unknowns and the load vector

In the basic equation, the elements x_i of the unknown vector \mathbf{x} are the moments at points i . The elements a_{i0} of the load vector \mathbf{a}_0 are the rotations due to external loads and actions at point i .

The inverse of the coefficient matrix

In order to perform the calculations, it is advisable to partition the coefficient matrix into second order blocks. For this purpose, let us assume that n is an even number, i.e. $n = 2m$.

Introducing

$$\mathbf{Z}_0 = \begin{bmatrix} 2 & 1 \\ 1 & 4 \end{bmatrix}, \quad \mathbf{Z} = \begin{bmatrix} 4 & 1 \\ 1 & 4 \end{bmatrix}, \quad \mathbf{Z}_m = \begin{bmatrix} 4 & 1 \\ 1 & 2 \end{bmatrix}, \quad \mathbf{V} = \begin{bmatrix} 0 & 0 \\ 1 & 0 \end{bmatrix},$$

the coefficient matrix can be written in the form

$$\begin{aligned}
\mathbf{P}_1 &= \mathbf{E}, \\
\mathbf{P}_2 &= \mathbf{B}_1^{-1} \mathbf{Y}_1, \\
\mathbf{P}_{q+1} &= \mathbf{B}_q^{-1} (\mathbf{Y}_q \mathbf{P}_q - \mathbf{B}_{q-1}^T \mathbf{P}_{q-1}), \quad q = 2, 3, \dots, m-1 \\
\mathbf{P}_0 &= \mathbf{Y}_m \mathbf{P}_m - \mathbf{B}_{m-1}^T \mathbf{P}_{m-1}, \\
\mathbf{Q}_m &= \mathbf{P}_0^{-1}, \\
\mathbf{Q}_{m-1} &= \mathbf{Q}_m \mathbf{Y}_m \mathbf{B}_{m-1}^{-1}, \\
\mathbf{Q}_q &= (\mathbf{Q}_{q+1} \mathbf{Y}_{q+1} - \mathbf{Q}_{q+2} \mathbf{B}_{q+1}^T) \mathbf{B}_q^{-1}, \quad q = m-2, m-3, \dots, 3, 2, 1
\end{aligned}$$

It is to be seen that only \mathbf{Q}_m needs the inversion of a single second order matrix.

The internal forces of the bridge

The load vector contains the rotations at the hinges of the primary system due to the uniform load between the points $2j$ and $2j+1$ (see **Fig. 5**):

$$\mathbf{a}_0 = \begin{bmatrix} 0 \\ \vdots \\ 0 \\ \mathbf{a}_{j0} \\ \mathbf{a}_{j+1,0} \\ 0 \\ \vdots \\ 0 \end{bmatrix}, \quad (12)$$

where

$$\mathbf{a}_{j0} = \frac{p}{E_s A} \begin{bmatrix} -\frac{1}{2} \frac{l_{2j}^3}{h^2} \\ \frac{l_{2j}^3}{h^2} - \frac{1}{2} \frac{l_{2j+1}^3}{h^2} - \gamma d^3 \end{bmatrix}$$

and

$$\mathbf{a}_{j+1,0} = \frac{p}{E_s A} \begin{bmatrix} -\frac{1}{2} \frac{l_{2j}^3}{h^2} + \frac{l_{2j+1}^3}{h^2} - \gamma d^3 \\ -\frac{1}{2} \frac{l_{2j+1}^3}{h^2} \end{bmatrix},$$

where $\gamma = \frac{E_s A}{24EJ}$.

To receive the unknown moments x_i ($i=1, 2, \dots, n$), let us introduce the notation

$$\mathbf{x} = \begin{bmatrix} \mathbf{x}_1 \\ \mathbf{x}_2 \\ \vdots \\ \mathbf{x}_{j-1} \\ \mathbf{x}_j \\ \vdots \\ \mathbf{x}_m \end{bmatrix}, \text{ where } \mathbf{x}_j = \begin{bmatrix} x_{2j-1} \\ x_{2j} \end{bmatrix}.$$

Then the inverse of the coefficient matrix with blocks \mathbf{R}_{qj} (see (10), (11)) has to be multiplied by the vector \mathbf{a}_0 shown in (12), and the moments are obtained in the following form

$$\mathbf{x}_q = E_s A d^2 h^2 \mathbf{P}_q \{ \mathbf{Q}_j \mathbf{a}_{j0} + \mathbf{Q}_{j+1} \mathbf{a}_{j+1,0} \}, \text{ if } q \leq j,$$

$$\mathbf{x}_q = E_s A d^2 h^2 \mathbf{Q}_q^T \{ \mathbf{P}_j^T \mathbf{a}_{j0} + \mathbf{P}_{j+1}^T \mathbf{a}_{j+1,0} \}, \text{ if } q \geq j,$$

and

$$\mathbf{Q}_j \mathbf{a}_{j0} = (\mathbf{Q}_{j+1} \mathbf{Y}_{j+1} - \mathbf{Q}_{j+2} \mathbf{B}_{j+1}^T) \mathbf{B}_j^{-1} \mathbf{a}_{j0},$$

$$\mathbf{Q}_{j+1} \mathbf{a}_{j+1,0} = (\mathbf{Q}_{j+2} \mathbf{Y}_{j+2} - \mathbf{Q}_{j+3} \mathbf{B}_{j+2}^T) \mathbf{B}_{j+1}^{-1} \mathbf{a}_{j+1,0},$$

further

$$\mathbf{P}_j^T \mathbf{a}_{j0} = (\mathbf{Y}_{j-1} \mathbf{P}_{j-1} - \mathbf{B}_{j-2}^T \mathbf{P}_{j-2})^T (\mathbf{B}_{j-1}^T)^{-1} \mathbf{a}_{j0},$$

$$\mathbf{P}_{j+1} \mathbf{a}_{j+1,0} = (\mathbf{Y}_j \mathbf{P}_j - \mathbf{B}_{j-1}^T \mathbf{P}_{j-1})^T (\mathbf{B}_j^T)^{-1} \mathbf{a}_{j+1,0}.$$

Finally, having the unknown x values which are the moments due to the external load at the intermediate supports, the moments M_c at an arbitrary cross section c can be calculated on the well known way:

$$M_\xi = M_{\xi_0} + \sum_i M_{\xi_i} x_i,$$

where M_{ξ_0} means the moment at cross section ξ of the primary system (see **Fig. 5**) due to the external load and M_{ξ_i} due to the unit moment on the primary system above the supports. The shear forces, and if needed the normal forces in the stiffening girder can be determined using the same principle, furthermore the forces S_k acting in the stay ended at point k of the stiffening girder. For latter, e.g., if the neighbouring d distances to node k are not loaded, the formula

$$S_k = \frac{x_{k-1} - 2x_k + x_{k+1}}{d h} l_k$$

can be used.

CONCLUSIONS

Comparing the system of linear equations, corresponding to the deformation method and the force method, respectively, it is interesting to notice certain similarities in the applied algorithms. Although the structure of the coefficient matrix for the two methods is quite different, after some transformations remarkable equivalence could be observed. According to the deformation method, the coefficient matrix consists of four tridiagonal boxes of order n , while the coefficient matrix obtained by the force method turned out to be a pentadiagonal matrix. (Of course, all these statements belong to the chosen primary systems.) It was not difficult to show in the first case that after appropriate rearranging of the equations and the unknowns (i.e. after an orthogonal transformation performed by a permutation matrix) the coefficient matrix became a block tridiagonal matrix consisting of second order blocks. In the other case, assuming that the order of the pentadiagonal matrix is even (this assumption can be made to see that the coefficient matrix can easily be partitioned such way), the resulting matrix becomes a block tridiagonal matrix consisting of second order blocks. Thus, in both cases, the structure of the inverse is similar, namely in each case we obtain a “one-paired” block matrix, and the same recursive algorithm can be applied for getting their blocks.

The study had different scopes. It has been shown that in special cases, it is possible to solve the equations both of deformation and force methods analytically. Another result is that the two basic methods of theory of structures can be compared. Some applications indicate that in case of gravitational loads, the deformation method is generally more advantageous. To study the forces caused by loading deformations (e.g. geometric inaccuracy of stay cables) the force method is preferable. The analytical solution gives an easier way for parametric studies for such structures which correspond to geometric and stiffness conditions supposed in this paper.

ACKNOWLEDGEMENT

The research work was carried out under an item of the Hungarian National Foundation for Scientific Research OTKA-T043034. The Authors express their gratitude for the support. The previous help of Dr. A. Farkas, Dr. I. Cserhalmi and Eng. S. G. Nehme are highly appreciated.

It is to be emphasised that this paper couldn't reach the Editorial Staff of this Finnish journal of high reputation without the kind encouraging of Professor Jutila. Professor Dr. tekn., Dr. h. c. Aarne Jutila started long ago to care for the close connection of the Helsinki University of Technology and the Budapest University of Technology and Economics. Personally, the Authors of this paper are proud of the cordial friendship which they enjoy in relation with Professor Jutila.

REFERENCES

- [1] Bevilacqua, R. Codenotti, B. Romani, F.: Parallel solution of block tridiagonal linear systems. *Linear Algebra and its Applications* 104. (1988) pp. 39...57.
- [2] Egerváry J.: Begründung und Darstellung einer allgemeinen Theorie der Hängebrücken mit Hilfe der Matrizenrechnung. *Abh. der IVBH* 16. (1956) pp. 149...184.

- [3] Farkas Gy.-Kovács T.-Péczely A.: *Cable-stayed bridges – Study aid.*(In Hungarian) Budapest University of Technology and Economics, 2003.
- [4] Korányi I.: *Theory of structures.* (In Hungarian), Vol. II/1, Tankönyvkiadó, Budapest, 1954.
- [5] Medved G. - Goschy B.: *Cable-stayed bridges. History, theory, detailing, construction.* (In Hungarian). Közlekedéstudományi Intézet, Budapest, 1990.
- [6] Palotás L.: *Theory and calculation of frames.* (In Hungarian.) Közl. Kiadó, Budapest, 1951.
- [7] Rózsa P.: *Linear algebra and its applications* (In Hungarian.) Tankönyvkiadó, Budapest, 1991.
- [8] Szabó J.-Roller B.: *Theory and calculation of bar structures* (In Hungarian.) Műszaki Könyvkiadó Budapest, 1971.

Tassi G.-Rózsa P.: Calculation of elasto-plastic redundant systems by applying matrix theory. (In Hungarian), *ÉKME Tudományos Közleményei.* IV/2 (1958), pp. 21...43.

Géza Tassi, Dr. Sc. (Tech), Professor
Pál Rózsa, Dr. Sc. (Math.), Professor

Budapest University of Technology and
Economics Department of Computer
Science and Information Theory, H-1521
Budapest
E-mail: geza_tassi@hotmail.com
E-mail: rozsa@cs.bme.hu

Mátyás Hunyadi, Civil Engineer,
Research Assistant

Budapest University of Technology and
Economics, Hungarian Academy of
Sciences Research Group for Computa-
tional Structural Mechanics,
H-1521 Budapest
E-mail: hunyadi@vbt.bme.hu